



Air Distribution in a Room and Airborne Transmission of Infectious Agents

by

Peter V. Nielsen

Aalborg University



Airborne Transmission of Infectious Agents in the Built Environment

- Measles
- Tuberculosis
- Chickenpox
- Influenza
- Smallpox
- Common cold
- SARS (The severe acute respiratory syndrome)
- (Avian influenza (H5N1) pandemic)
- Anthrax

Test Room for Study of Cross Infection

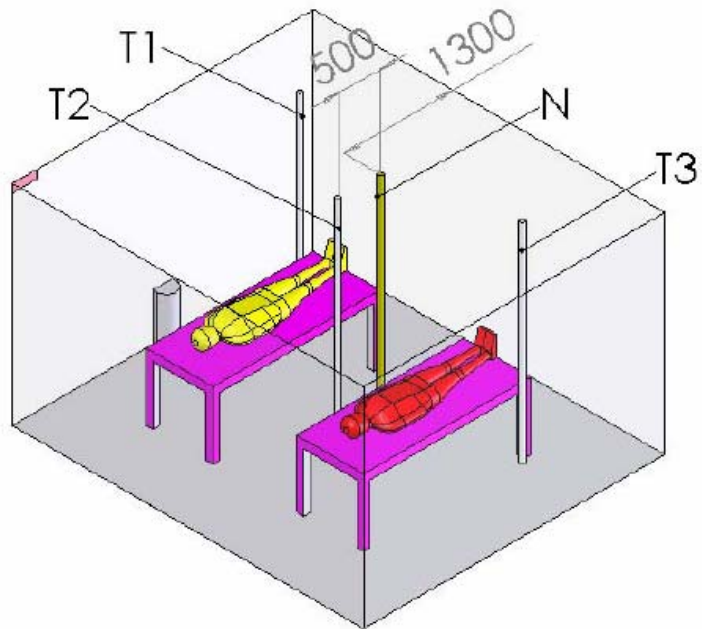

Exposure Level

$c_R q_o$



Personal exposure index $\epsilon_{exp} = c_R/c_{exp}$

$c_R = c_{exp}$ mixing ventilation





$c_R > c_{exp}$ ADS optimized for cross infection

Exposure level $c_{exp} = S (1/q_o) \cdot (1/\epsilon_{exp})$

Low exposure High flow rate High exposure index

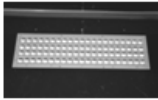
Different Air Distribution Systems

Systems which can handle a high flow rate are important, but some systems are better than others with respect to a high personal exposure index.

System	Supply	Return	
Mixing ventilation	End wall-mounted	Return opening below supply terminal	
Mixing ventilation	Ceiling swirl diffuser	End wall-mounted below ceiling	
Mixing ventilation	Radial ceiling diffuser	End wall-mounted below ceiling	
Displacement ventilation	End wall-mounted	End wall-mounted below ceiling	
Vertical ventilation	Ceiling-mounted low impulse textile terminal	End wall-mounted at floor level	

Air Distribution with Downward Ventilation

The air distribution in the room is controlled by buoyancy forces from the heat sources, although the flow from the terminal can be characterized as a passive displacement flow with a downward direction in areas without thermal load.

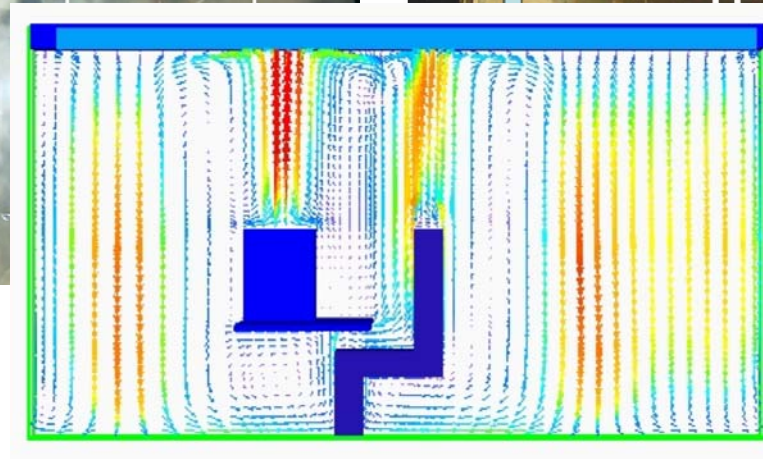
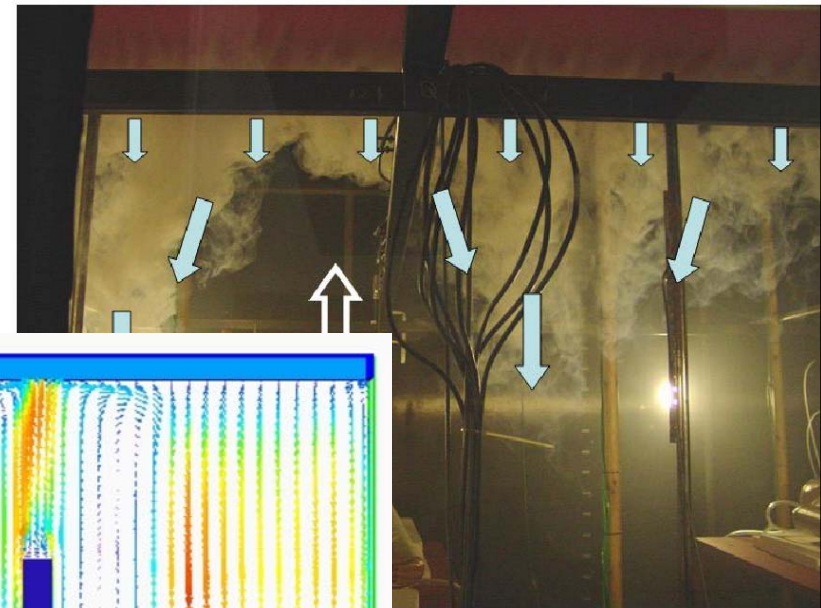

Air Distribution with Downward Ventilation

The displacement flow is efficient outside the occupied areas.

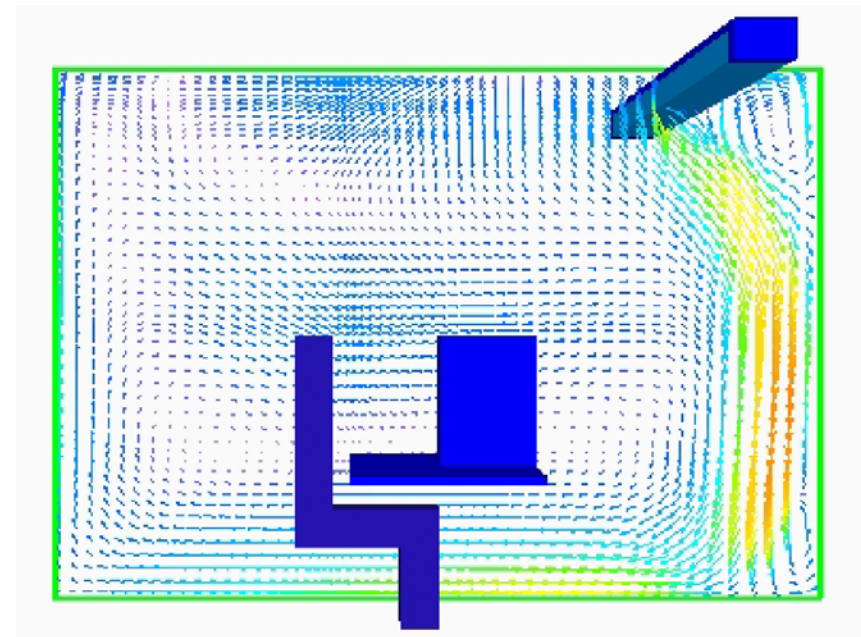
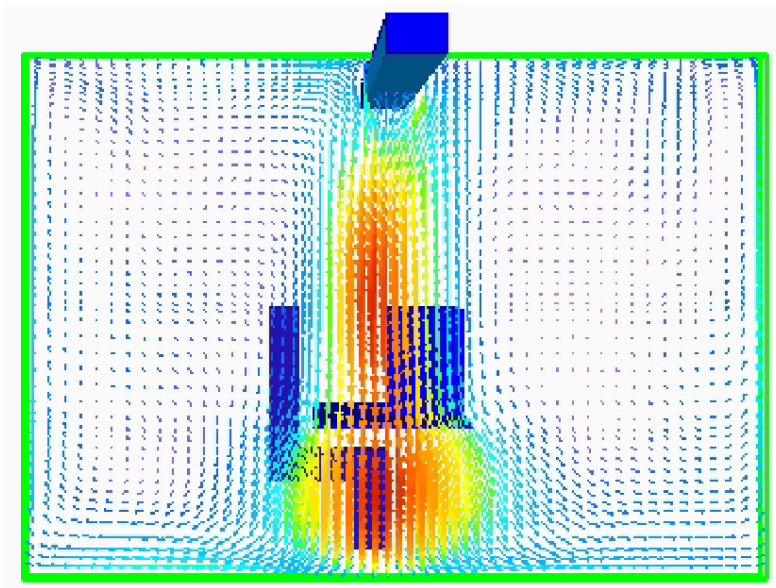



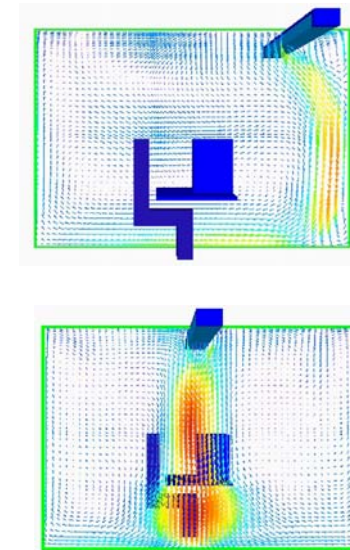
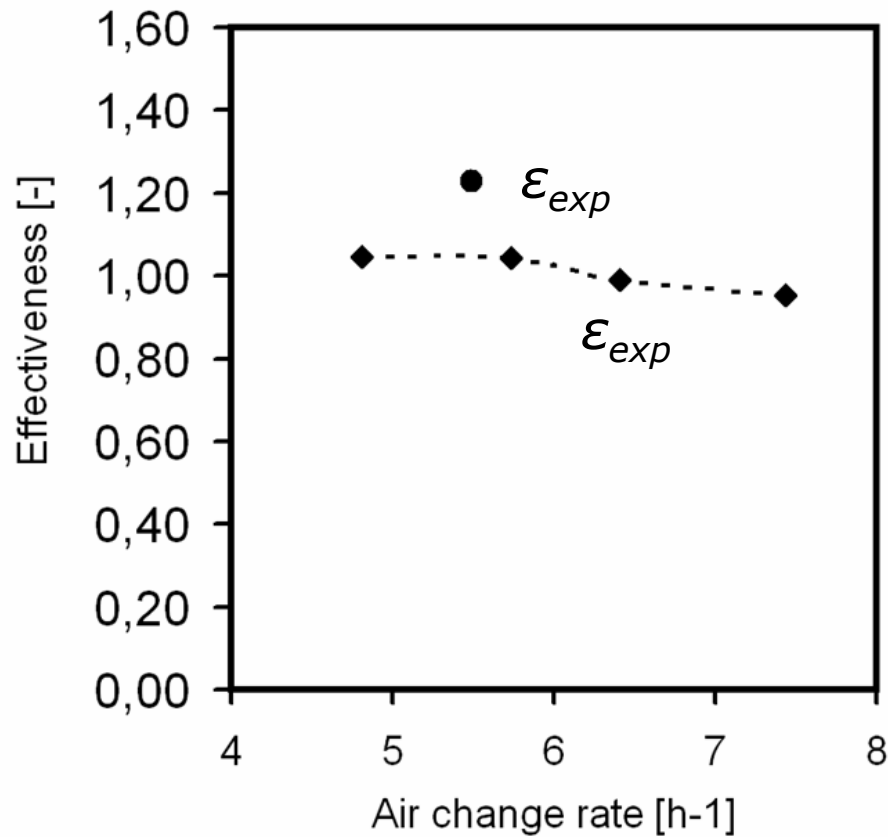

Ventilation Effectiveness and Exposure

Personal exposure index $\epsilon_{exp} = c_R/c_{exp}$

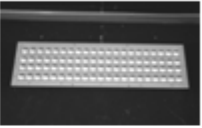

Different Air Distribution Systems

System	Supply	Return	
Mixing ventilation	End wall-mounted	Return opening below supply terminal	
Mixing ventilation	Ceiling swirl diffuser	End wall-mounted below ceiling	
Mixing ventilation	Radial ceiling diffuser	End wall-mounted below ceiling	
Displacement ventilation	End wall-mounted	End wall-mounted below ceiling	
Vertical ventilation	Ceiling-mounted low impulse textile terminal	End wall-mounted at floor level	

Personal Exposure Index, Displacement Ventilation



Test 5 [1m, 4ACH, Displacement, Facing up, Mouth]

Test 6 [1m, 4ACH, Displacement, Facing up, Nose]

Test 11 [1m, 4ACH, Displacement, Face to Face, Mouth]

Test 12 [1m, 4ACH, Displacement, Face to Face, Nose]

Test*	ϵ_e
5	64.8(55.3-86.70)
6	69.9(52.6-93.20)
11	0.75(0.47-1.83)
12	8.75(5.04-18.75)

Displacement Ventilation, Stratification of Exhalation

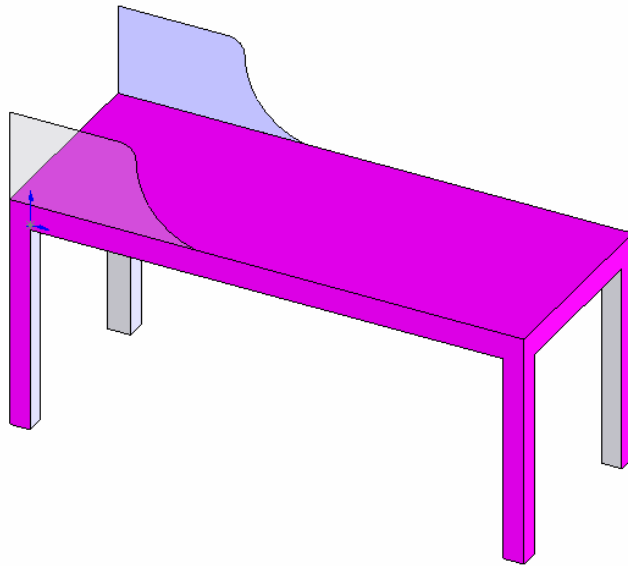

CFD predictions

Vertical concentration gradient, measurements and predictions.

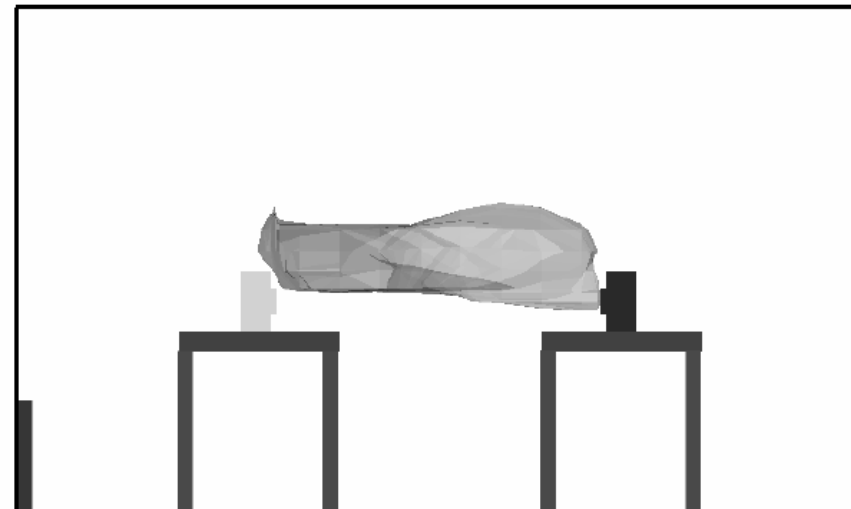

Vertical Temperature Gradient, Displacement Ventilation

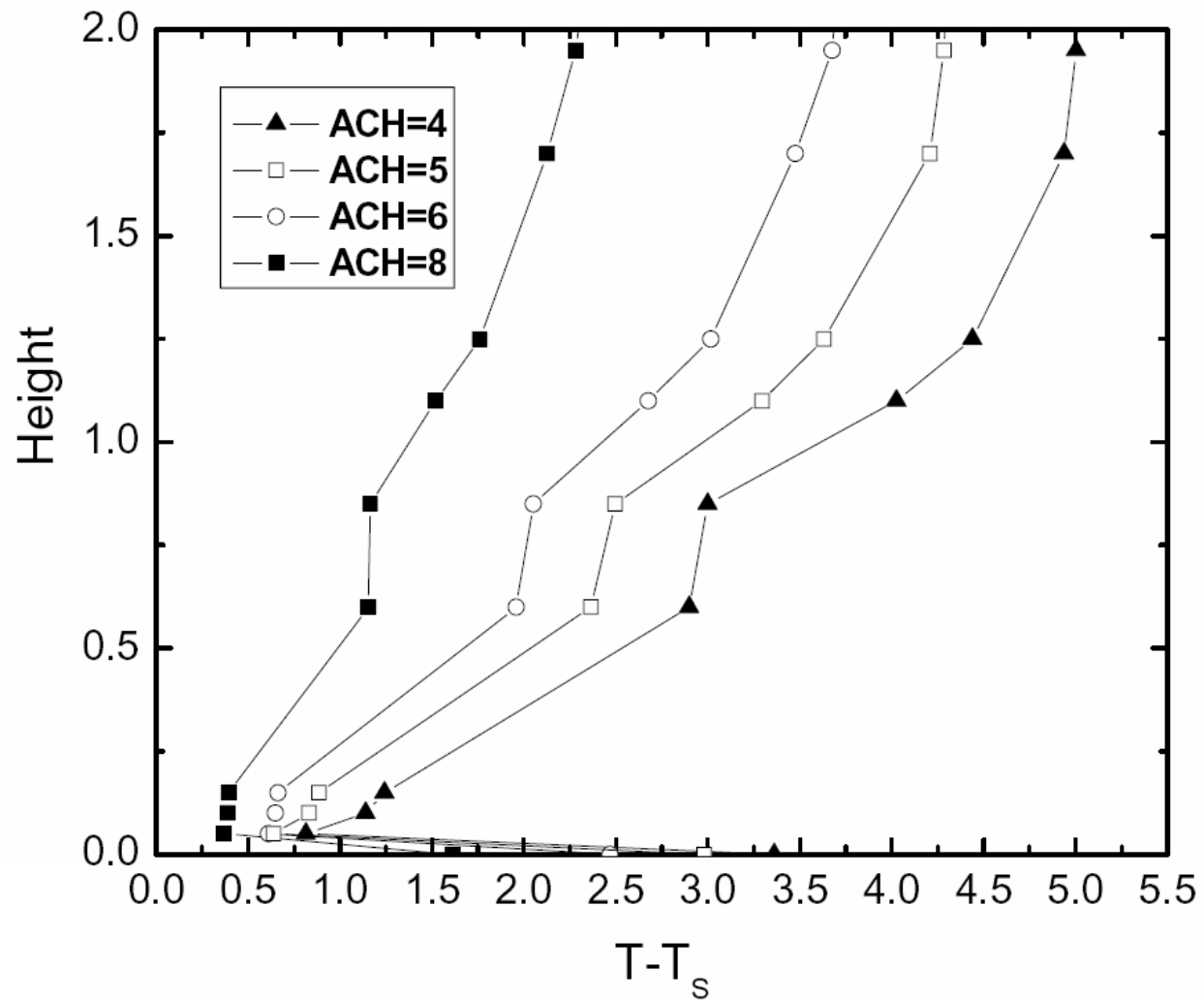

Large ACH and Displacement Ventilation

4 ACH

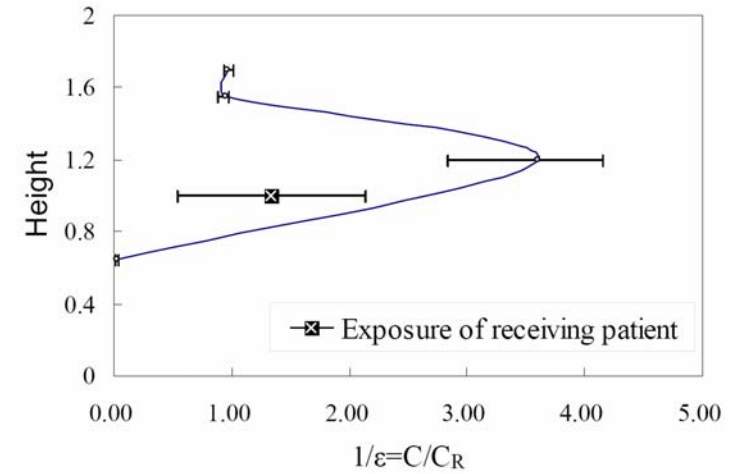

8 ACH

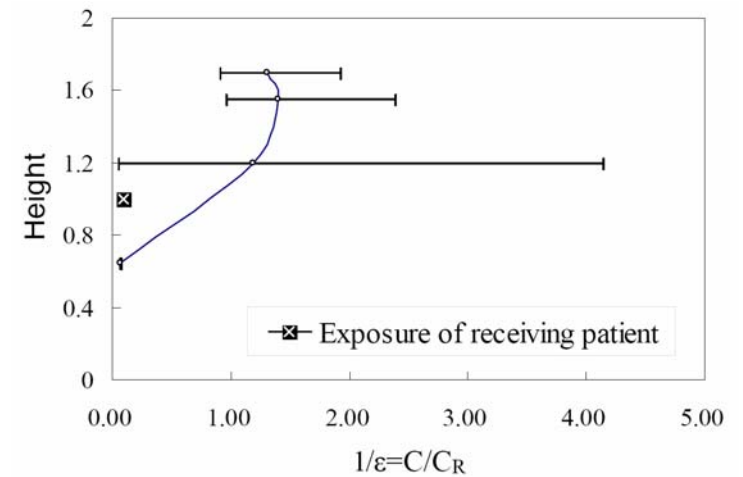

Local Ventilation

Personalized ventilation
protects the person

Local exhaust is efficient
to decrease the source



Peter V. Nielsen, Aalborg University

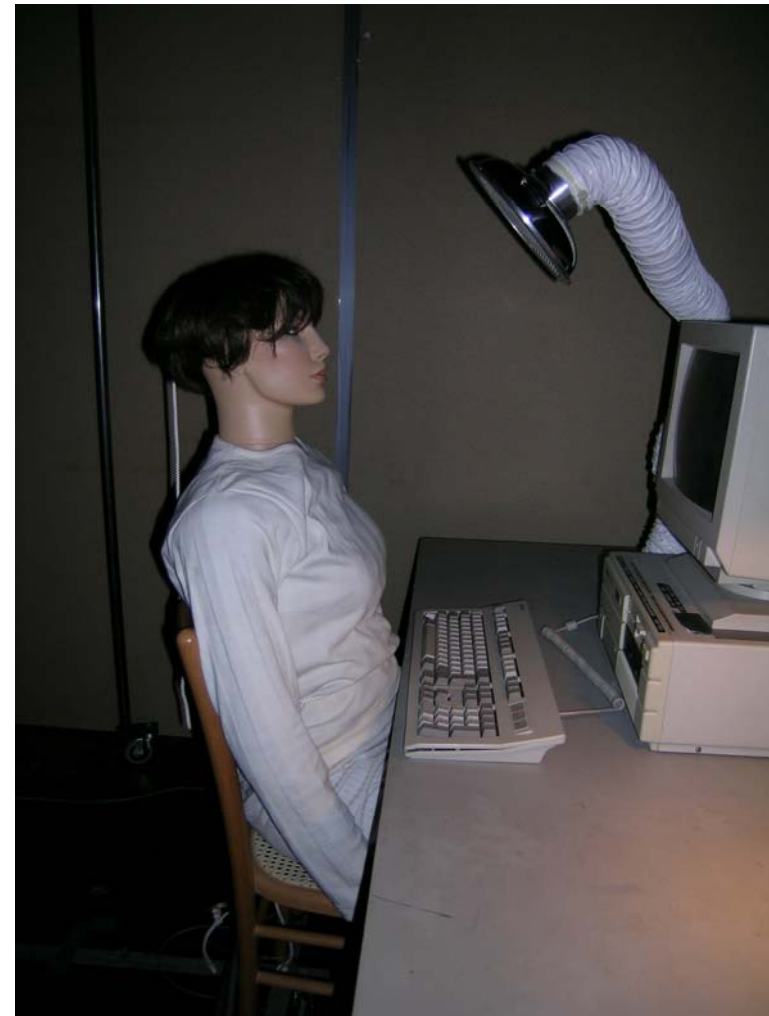

pvn@civil.auc.dk

Presonalized Ventilation

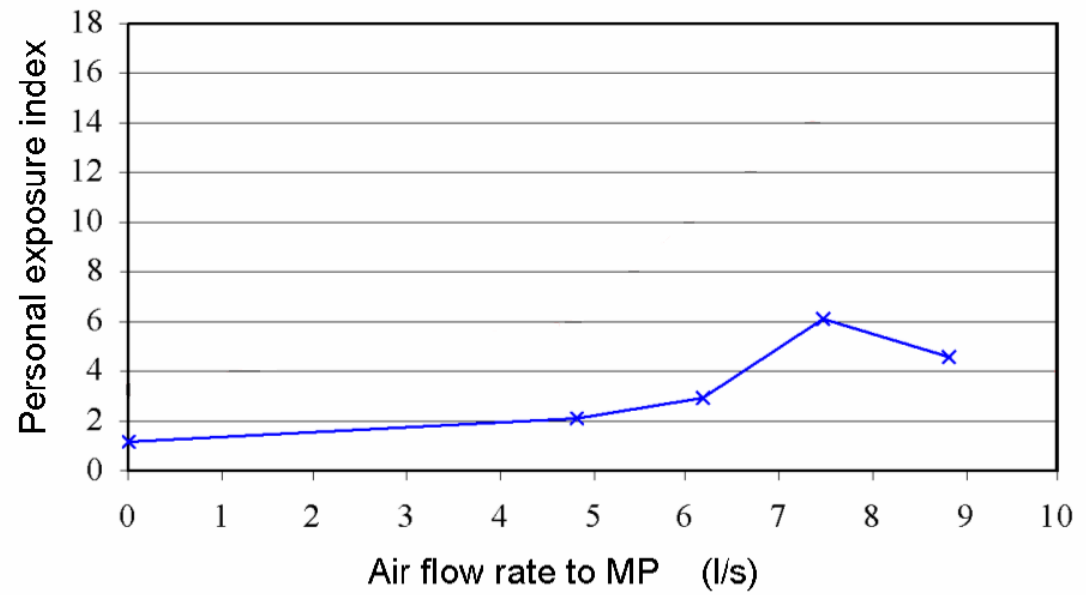
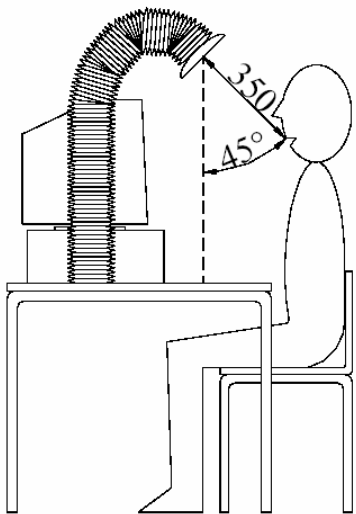

Conclusions

$$\text{Exposure level } c_{exp} = S (1/q_o) \cdot (1/\varepsilon_{exp})$$

The different systems have only minor variation in the exposure index. A system which can handle a high flow rate without draught is therefore a system where the concentration level can be reduced with success.

Vertical ventilation has a large element of mixing.

Displacement ventilation requires a high flow rate to show a two zone effect with low exposure index. The system can create bad results at a conventional air change rate.

Local exhaust at the source is efficient.

Personalized ventilation is efficient as a protection of Persons.



Literature

H. Qian, Y. Li, P. V. Nielsen, C. E. Hyldgaard, T. Wai Wong and A. T. Y. Chwang, Dispersion of Exhaled Droplet Nuclei in a Two-Bed Hospital Ward with Three Different Ventilation Systems. *Indoor Air*, Volume 16, no. 2, pp. 111 – 128, 2006.

P. V. Nielsen, C. E. Hyldgaard, A. Melikov, H. Andersen and M. Soennichsen, Personal Exposure between People in a Room Ventilated by Textile Terminals – with and without Personalized Ventilation. *Indoor Air 2005*, The 10th International Conference on Indoor Air Quality and Climate, Beijing, 2005, China.

H. Qian, P. V. Nielsen, Y. Li, C. E. Hyldgaard, Dispersion of Exhalation Pollutants in a Two-Bed Hospital Ward with Downward Ventilation System. *Indoor Air 2005*, The 10th International Conference on Indoor Air Quality and Climate, Beijing, 2005, China.

Hua Qian, Peter V. Nielsen, Yuguo Li and Carl E. Hyldgaard. Airflow and Contaminant Distribution in Hospital Wards with a Displacement Ventilation System. The 2nd International Conference on Build Environment and Public Health, BEPH 2004, Shenzhen, China.